

J MOLD-FCP: J Mold for Fiber Cement Panel

- Available in Aluminum Alloy (6063 T-5)
Used as a termination molding to case off the fiber cement panel.
- Note:** Attach panel per manufacturer's recommended installation instructions.

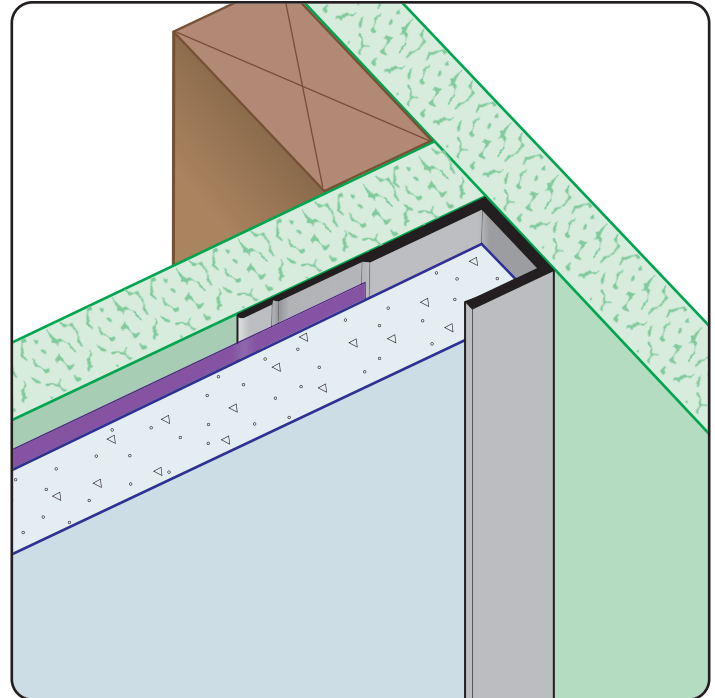

Most Common Sizes

Length: 10'

Materials And Finishes:

Details: stpro.us/EXT
Aluminum Alloy (6063 T-5)

ASTM Codes:

Details: stpro.us/ASTM
AA-M32-C10A21, AAMA 605.2, C841, C1047, C1063, B136-84, B244-97, D4214-98, ND1730-67-TYPE B

Most Common Part Numbers:

- J MOLD FCP375EC** J MOLD-FCP: X=3/8, Clear Anod, A, 10'
- J MOLD FCP375ECH** J MOLD-FCP: X=3/8, Chem-Film, A, 10'
- J MOLD FCP375EK** J MOLD-FCP: X=3/8, Fluorophore Paint, AL, 10'
- J MOLD FCP375EP** J MOLD-FCP: X=3/8, Powder Coated, AL, 10'

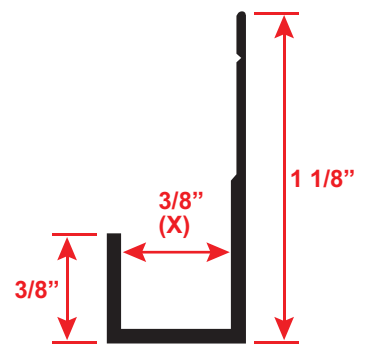

| | | | |
|--------------|------------------|-------------------------------------|--------------------|
| QUOTE | Company: _____ | QTY: _____ | PO Number: _____ |
| | Name: _____ | Material: Aluminum Alloy (6063 T-5) | Job/Project: _____ |
| | Address: _____ | Length: _____ | Notes: _____ |
| | City: _____ | | _____ |
| | State/ZIP: _____ | | _____ |
| | Phone: _____ | | _____ |
| | eMail: _____ | | _____ |

877-786-2587 • StocktonProducts.com

