



CUSTOM SIZES AVAILABLE!

Stockton Custom Fabrication

877-786-2587

custom@StocktonProducts.com



PRODUCTS™

SBX: Stud Blocking

- Custom Sizes Available, Contact Customer Service For Details
- Available in 3 5/8", 4", 6" And 8" Standard Widths
- Available in Galvanized Steel (GS)

The Stub Blocking provides horizontal bracing for studs and joists. Designed for 12", 16", and 24" stud layouts with a precut flange to fit between the studs for easy installation. Provides full bearing between the wall stud webs along the shear wall and prevention load transfer issues.

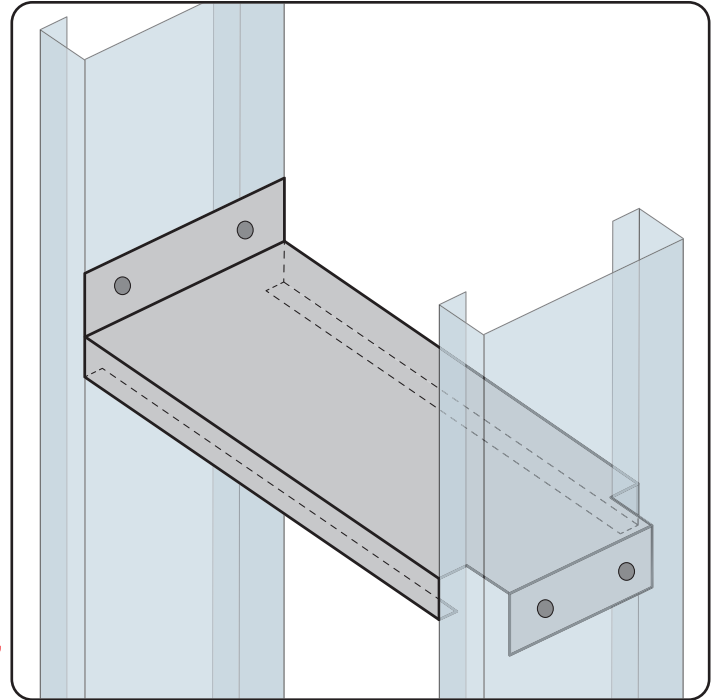

Most Common Sizes

X Sizes: 3 5/8", 4", 6" or 8"

Y Sizes: 12", 16" or 24"

Z Sizes: 1 5/8"

Materials And Finishes:

Details: stpro.us/MET

Galvanized Steel (GS)

ASTM Codes:

Details: stpro.us/ASTM

All Accessories are fabricated from prime galvanized steel G90 zinc coating by the hot dipped method, conforming to steel and coating specification ASTM A-653/A-653M or zinc alloy meeting ASTM B-69. Stainless Steel A480/A480M A580M (Stainless Steel) For installation and placement instructions refer to ASTM C1063, C841 and C926.

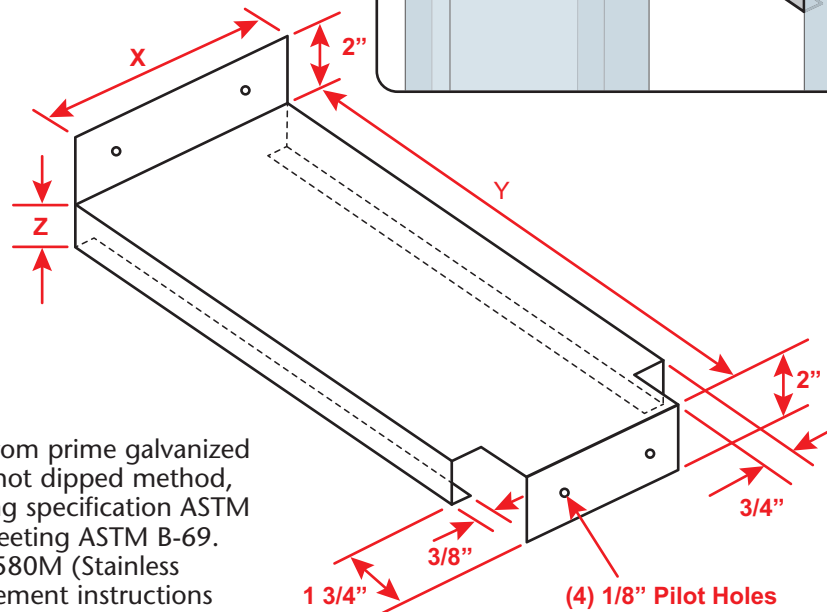

QUOTE

Company: _____
 Name: _____
 Address: _____
 City: _____
 State/ZIP: _____
 Phone: _____
 eMail: _____

QTY: _____
 Material/Gauge: _____
 X Size: _____
 Y Size: _____
 Z Size: _____

PO Number: _____
 Job/Project: _____
 Notes: _____

877-786-2587 • StocktonProducts.com

