



**CUSTOM SIZES AVAILABLE!**

Stockton Custom Fabrication  
877-786-2587  
custom@StocktonProducts.com



# TFBO: TruFlush™ Backing Makeup Open Side

- Faster Installation
- Eliminates Costly Backcharges
- Increase Production Installation, Plus Drywall, Taping And Finishing
- Increased Safety, No Grinders Needed, Only Chop Saw And Screw Gun
- Galvanized Steel (GS)
- Patent Pending

Low profile backing that provides increased load capacity. TruFlush™ Backing Makeup Open Side will eliminate build up, drywall cracking and drywall fastener popping. Available in 20 gauge or 16 gauge for various stud spacing. **Note:** Custom spacing and steel thickness available with extended lead times.

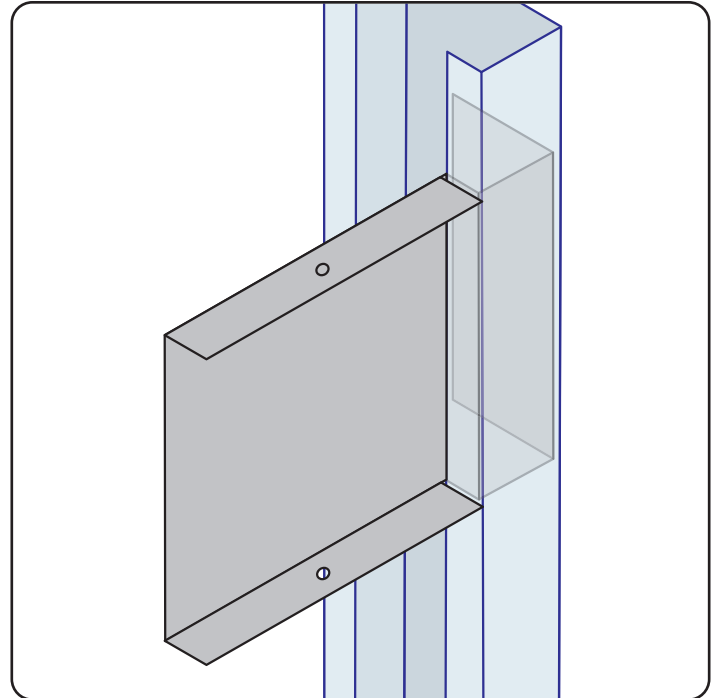

See Installation Guide For Load Testing Data

## TRUFLUSH™

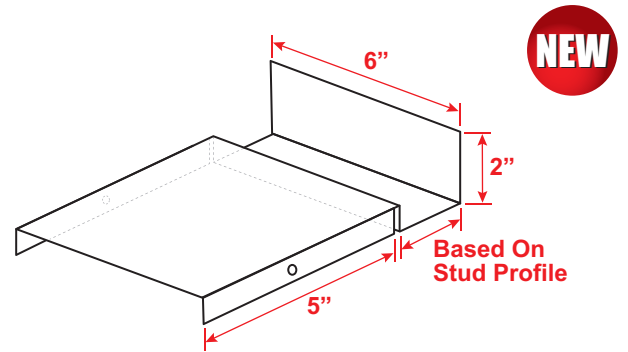
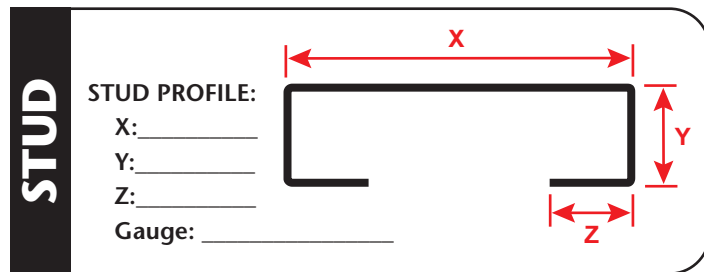

### Materials And Finishes:

Details: [stpro.us/MET](http://stpro.us/MET)

Galvanized Steel (GS) in 20 ga. or 16 ga.  
G60 standard (G90 optional)

### ASTM Codes:

Details: [stpro.us/ASTM](http://stpro.us/ASTM)

A1003, A653, A924, C645, C754, C955

**QUOTE**

Company: \_\_\_\_\_ QTY: \_\_\_\_\_ PO Number: \_\_\_\_\_

Name: \_\_\_\_\_ Material/Gauge: \_\_\_\_\_ Job/Project: \_\_\_\_\_

Address: \_\_\_\_\_ Notes: \_\_\_\_\_

City: \_\_\_\_\_

State/ZIP: \_\_\_\_\_

Phone: \_\_\_\_\_

eMail: \_\_\_\_\_

877-786-2587 • [StocktonProducts.com](http://StocktonProducts.com)

